

Wonder Comprehension

Wonder p. 88-90

Part A

1. On page 88-89, Via describes August's face. Make notes on August's eyes and mouth in spidergram form.

2. Close your eyes and imagine what August's face looks like, feature by feature. Spend about a minute with your eyes closed, imagining every part of August's face. You might need to reread pages 88-89 and close your eyes for a second time.

3. Reread page 17 and think about Mrs Garcia's reaction. What do you think about her reaction after reading Via's description of August's face?

4. There are no illustrations of August in the book? Why not?

5. Why do you think the author gives such a detailed description of August's face?

6. Why doesn't Via speak to him about the hearing aids?

7. Why was August easier to 'read' before the surgeries?

8. Why is Via frustrated with August? Give evidence from the text that backs up your opinion.

Wonder Comprehension

Wonder p. 88-90

Part B

1. Why do you think the author has waited until this point in the book to describe August's face in detail?

2. On page 89, Via compares August with Grans. Explain this comparison.

3. Which word on page 90 recalls another part of the chapter? Explain your answer.

4. On page 90, What does Via think of her family's treatment of her brother? Can you find two examples elsewhere in the text to illustrate this?

5. Why do you think the author has introduced Via as narrator at this point in the book? Give two reasons and explanations for your answers.

6. How does Via's narration change our view of August? Give two reasons with explanations.

7. Why does the author have Via describing August's face instead of Mom, Jack or Julian?

Challenge Task

Watch the video of a woman with facial disfigurement. Take your time watching the video and in that time, think about your own reaction about the way her face looks. Be open in your reaction and think about how some of the characters react towards August. Write down your thoughts as there will be the opportunity to discuss this as a class.

A series of horizontal lines for writing an answer to the challenge task.

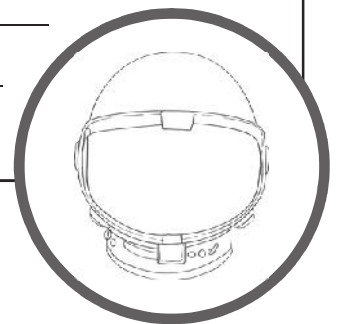

Wonder Comprehension Answers

Part A

1. On page 88-89, Via describes August's face. Make notes on August's eyes and mouth in spidergram form.

Example answers could include:

<i>Eyes</i>	<i>Mouth</i>
<i>Inch below 'normal'</i>	<i>Gash from upper lip to nose</i>
<i>Slant downwards</i>	<i>Teeth small and splayed out</i>
<i>Diagonal slits</i>	<i>Overbite</i>
<i>Bulge outwards</i>	<i>Undersized jawbone</i>
<i>Top lids half closed</i>	<i>Small chin</i>
<i>Lower lids sag</i>	
<i>Can see red part of eyes</i>	
<i>No eyebrows or lashes</i>	

2. Close your eyes and imagine what August's face looks like, feature by feature. Spend about a minute with your eyes closed, imagining every part of August's face. You might need to reread pages 88-89 and close your eyes for a second time.

No written response.

3. Reread page 17 and think about Mrs Garcia's reaction. What do you think about her reaction after reading Via's description of August's face?

Various answers, perhaps focusing on understanding her discomfort with August's appearance or a better understanding of how she felt than they had when they first read page 17.

4. There are no illustrations of August in the book? Why not?

Answers focus on using imagination from the description or from the story. For example: There are no illustrations of August because everyone will have their own picture of how August looks. If the author had supplied her own illustration, there would be a single image of August and that might limit how we see him in our imaginations. No illustration means that we must imagine his looks through the description.

5. Why do you think the author gives such a detailed description of August's face?

Example answers: The author gives us such a detailed description because she wants us to have a vivid picture of August from this point forwards.

So far, we've not had any description – we've almost ignored what August looks like and we need to see the reality of August's situation for ourselves.

6. Why doesn't Via speak to him about the hearing aids?

Example answers: Via doesn't speak to August about the hearing aids because she knows that he knows people are more concerned with his facial disfigurement than they would be with a new hearing aid.

They don't speak to one another about August's problems – on page 89, Via says she wishes she could 'ask him about this stuff'.

7. Why did Via find August easier to 'read' before the surgeries?

Example answer: Via found August easier to 'read' because there were very simple signs of simple emotions. Now his face can make more complex movements and he has more complex emotions because he's growing up. Via is also growing up, so she is seeing more complexity in her view of August than she did when she was younger.

8. Why is Via frustrated with August? Give evidence from the text that backs up your opinion.

Answers will vary.

Part B

1. Why do you think the author has waited until this point in the book to describe August's face in detail?

Example answer: I think the author has waited until page 88 to describe August's face because we needed to get to know August and accept him in the way the people who love him do before we got to know his physical features. Our understanding of and love for August helps us to see his facial disfigurement in a more mature way.

2. On page 89, Via compares August with Grans. Explain this comparison.

Example answer: Grans' face has changed over time. She used to be a pretty girl but then the wrinkles formed on her face. She looked different, older and some might say not 'pretty' any more, but Grans had a beautiful personality (p. 85) which meant that her looks were a part of her personality and she was 'beautiful' as a whole person. August's looks aren't 'pretty' either and his personality is attractive or 'beautiful' in the same way.

When Grans looked in the mirror, she might see the pretty girl from Ipanema underneath the 'deformity' of wrinkles; when August looks, he might see his true personality or his face as it would be without the disfigurement.

3. Which word on page 90 recalls another part of the chapter? Explain your answer.

Circle.

Example answer: At the beginning of Via's narration, she described the family as 'orbiting' August. She is criticising the way her family behaves towards August in the way that he is still the centre of attention even though he has grown up and does not need the amount of medical treatment he needed earlier in life.

4. On page 90, What does Via think of her family's treatment of her brother? Can you find two examples elsewhere in the text to illustrate this?

Via thinks the family treat August like a baby. Various examples throughout the text so far, e.g. Mom calls him honey at various points, Dad brings up the Auggie Doggie cartoon.

5. Why do you think the author has introduced Via as narrator at this point in the book? Give two reasons and explanations for your answers.

Example answer: The author has introduced Via as narrator so that we can have another perspective on the family's situation. So far, we have only had August's view and his view is limited by his understanding of situations (e.g. Via's 'crying meltdown', Mr Tushman's Mr T joke). Via is older and has a different, more mature understanding of August's situation.

Via's view also gives the reader a better understanding of what the rest of the family go through in dealing with August's situation. It makes us realise that the people supporting August are real, have feelings of their own and aren't perfect.

6. How does Via's narration change our view of August? Give two reasons plus explanations

Example answers: Via's narration helps us to see that August can be focused on himself (he wasn't too bothered about Via's 'crying meltdown', but he's only ten).

It gives us a clear view of what it's like for the family living with August's difficulties over the years and some of the sacrifices that they've made to look after him.

Via's narration helps us see that August is not necessarily the centre of the world (as his parents have treated him) but that he is just another character or another person. It's a more realistic view – the realistic description of his face and Via's reaction to it when she returned from Grans' illustrates this.

7. Why does the author have Via describing August's face instead of Mom, Jack or Julian?

Example answer: Via loves August, her description is clear and honest, without either sentimentality or cruelty. Julian would have made fun of August in the description, Jack might also have done (judging by his behaviour on page 77) – he wouldn't have been able to describe it in such detail as he doesn't seem to take that much notice of August's face at other times. Mom would likely have been emotional and sentimental about August's face – she's not as detached as Via. Via is a little older than Jack and Julian, so her description is more mature than theirs would have been; it's more candid than Mom's would have been because she's a teenager and is happy to be blunter than an adult might be.

★ Challenge Task ★

Answers will vary.